

- **Langsamlaufender Gerotor-Motor**
 - **Spezielle Orbital-Steuerung**
Geringe interne Leckage
Hoher volumetrischer Wirkungsgrad
 - **Rollen im Rotorsatz**
Reduzierte Reibung
Lange Lebensdauer
 - **Patentierter Hochdruckwellendichtung**
Keine Leckölleitung
Keine Rückschlagventile
 - **Vielzahl von Varianten**
Großer Einsatzbereich
-
- **Moteur lent système Gerotor**
 - **Une distribution orbitale particulière assurée**
fuites internes minimales
rendements volumétriques élevés
 - **Le rotor à rouleaux**
réduit les frottements
augmente la durée de vie
 - **Par l'utilisation de joints d'arbre haute pression brevetés**
pas de conduite de drainage
pas de clapets anti-retour
 - **Grâce à de nombreuses variantes**
larges domaines d'application
-
- **Low Speed Gerotor Motor**
 - **Zero leak commutation valve**
For greater, more consistent volumetric efficiency
 - **Roller vane rotor set**
Reduces friction and internal leakage
Maintaining efficiency throughout the life of the motor
 - **A patented high-pressure shaft seal**
No check valves needed
No extra plumbing
 - **Wide choice of displacement range, flange and shaft options**
Greater efficiency in systems design to suit your application
-
- **Motore orbitale a bassa velocità**
 - **Una particolare distribuzione orbitale assicurata**
trafilamento ridotto
elevato rendimento volumetrico
 - **Con lo statore a rullini**
si riduce l'attrito interno
si mantiene nel tempo l'efficienza del motore
 - **Una guarnizione di tenuta ad alta pressione brevettata elimina la necessità**
di una linea di drenaggio esterna
e di valvole di non ritorno
 - **Un'ampia gamma di cilindrata, flange ed alberi**
consentono scelte adeguate ad ogni esigenza costruttiva

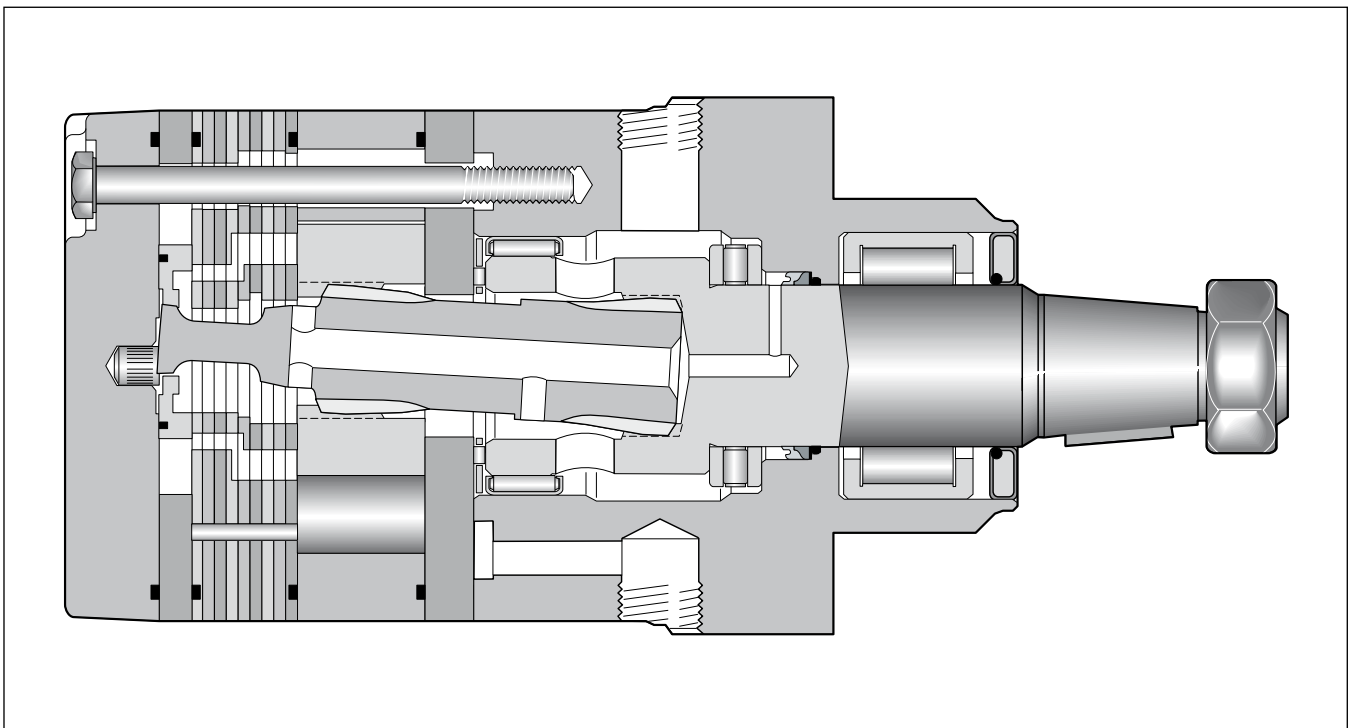

Performance

Drehzahl Speed Vitesse de rotation Velocità di rotazione	5...710 rev/min
Schluckstrom Oil flow Débit d'huile Portata	max. 115 l/min
Eingangsdruck Supply pressure Pression entrée Pressione in entrata	max. 300 bar
Drehmoment Torque Couple Coppia	max. 1490 Nm
Seitenlast Side load Charges latérales Carico radiale	max. 30.000 N

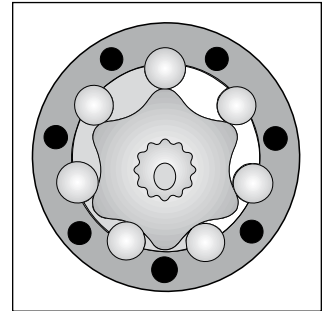
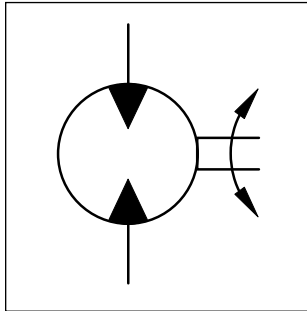

Motor series TH	Geom. Schluckvolumen Geometric displacement Cylindrée	Max. Drehzahl Max. speed Vitesse de rotation maxi Velocità di rotazione maxi	Max. Schluckstrom Max. oil flow Débit d'huile max Portata max	Max. Druckdifferenz Max. differential pressure Chute de pression maxi Caduta di pressione max	Max. Eingangsdruck Max. supply pressure Pression maxi entrée Pressione max in entrata	Max. Drehmoment Max. torque Couple maxi Coppia max	Max. Leistungabgabe Max. performance Puissance de sortie maxi Potenza meccanica max	Min. Anlaufmoment Min. starting torque Couple min. fourni Coppia min. di spunto
	cm ³ /U cm ³ /rev cm ³ /tr cm ³ /giro	cont / int U/min rev/min tr/min giri/min	cont / int l/min	cont / int bar	max bar	cont / int Nm	cont / int max. KW	cont / int Nm
TH 140	140	460/660	75/100	200/280	300	400/540	33	320/430
TH 170	169	400/560	75/100	200/280	300	485/650	33	380/540
TH 195	195	340/480	75/100	200/280	300	560/770	33	450/620
TH 240	237	270/400	75/100	200/280	300	685/920	32	550/740
TH 280	280	230/340	75/100	200/280	300	800/1100	31	640/880
TH 335	337	190/280	75/100	200/280	300	980/1350	30	790/1080
TH 405	405	170/240	75/100	170/240	300	960/1350	27	770/1080
TH 475	476	150/240	75/115	140/200	300	960/1400	28	770/1120
TH 530	529	130/220	75/115	140/170	300	1050/1280	23	840/1024
TH 625	624	110/190	75/115	120/160	300	1040/1360	20	830/1090
TH 785	786	90/150	75/115	100/140	300	1150/1490	17	920/1200
TH 960	958	80/120	75/115	70/100	300	925/1390	12	740/1110

int. =
Intermittierende Werte maximal: 10% von jeder Betriebsminute.
Intermittent operation rating applies to 10% of every minute.
Fonctionnement interm.: 10% max. de chaque minute d'utilisation.
Servizio intermittente: 10% max di ogni minuto di utilizzazione.

Code M

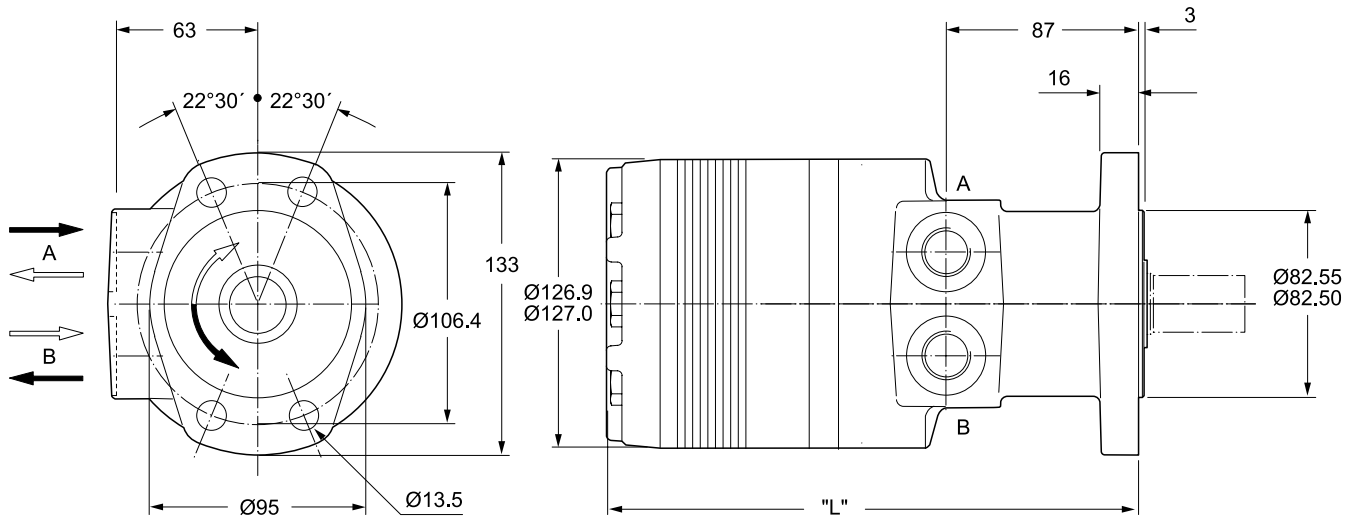

Code U

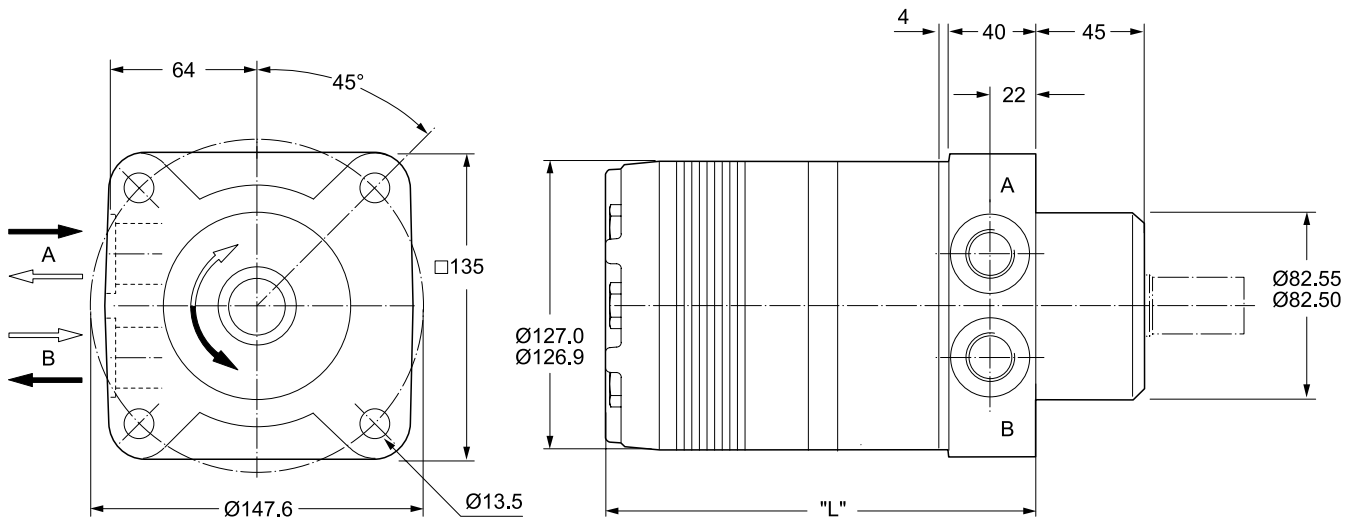

Gewicht / Weight		TH140	TH170	TH195	TH240	TH280	TH335	TH405	TH475	TH530	TH625	TH785	TH960
Poids / Peso	kg	17.0	17.2	17.4	17.8	18.2	18.6	19.2	19.8	20.6	21.3	22.9	24.5
Code M	"L" mm	216	219	222	227	232	238	245	254	260	270	289	308
Code U	"L" mm	173	177	180	184	189	196	203	212	218	227	246	265

Ports

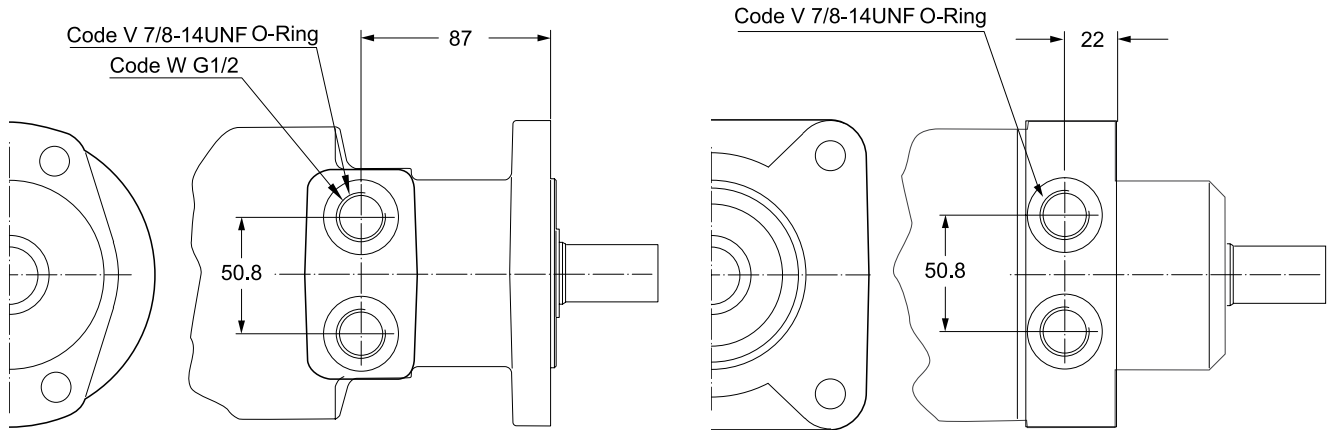

**Coupling shaft
 Code 31**

Code 32

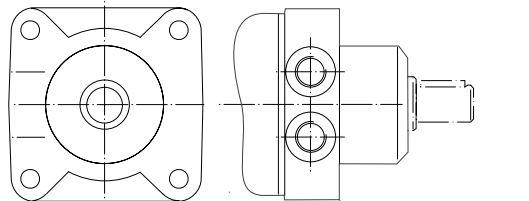
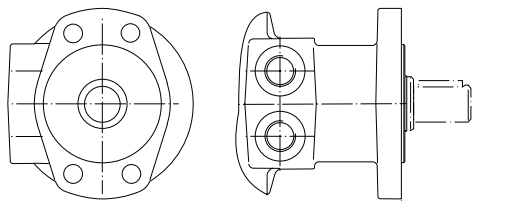
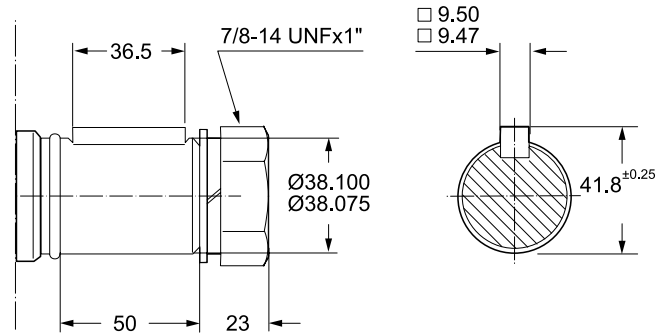
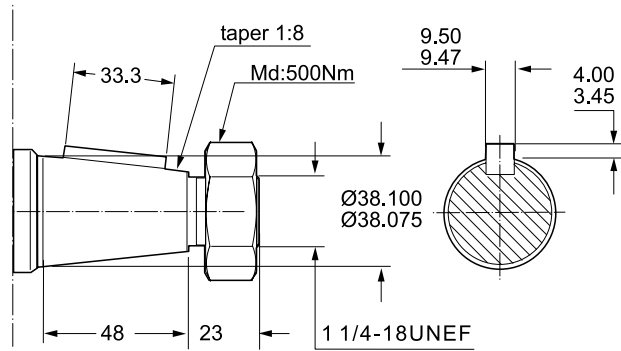

Code 31

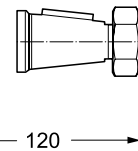
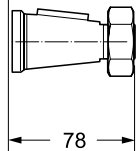

Code 32

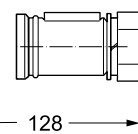
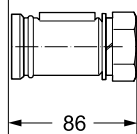

Code B 7/8-14UNF **Code X** G 1/2

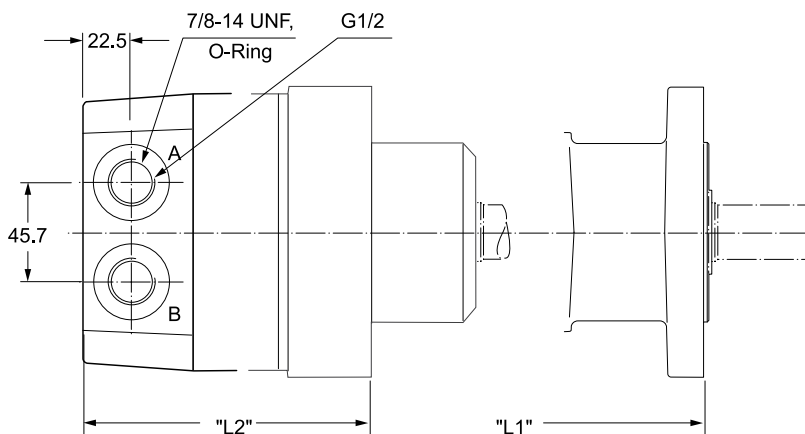
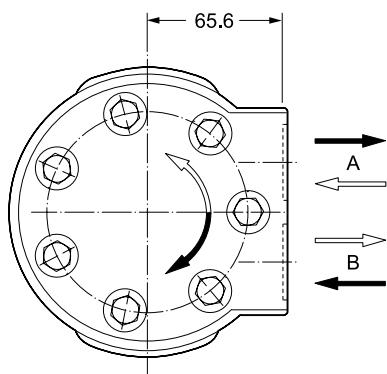

Code A 7/8-14UNF **Code Y** G 1/2

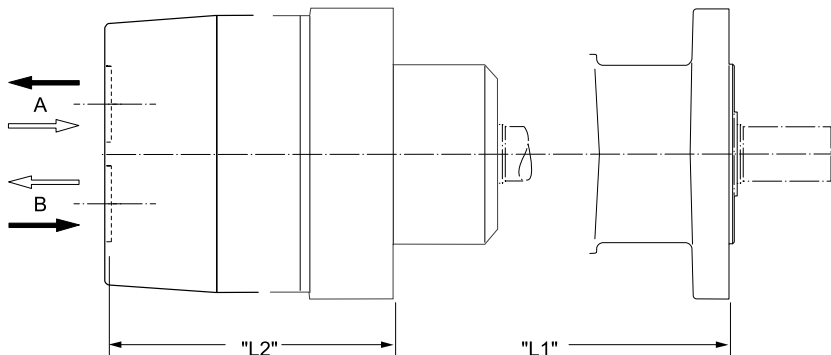
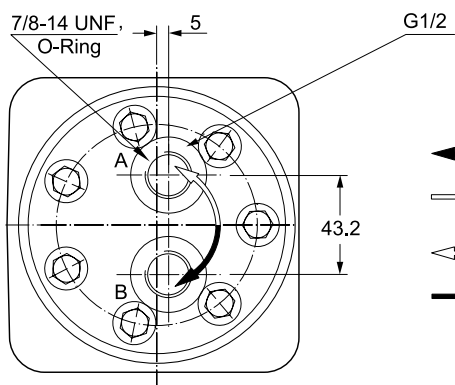

Code L

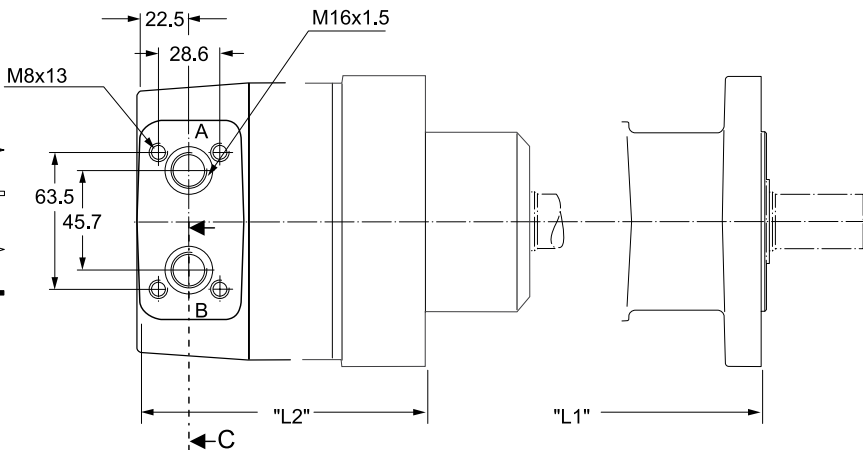
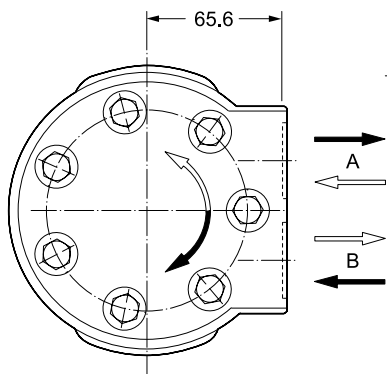

Section C

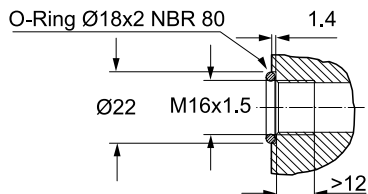

Zum Motor mit Universalanschluss werden 2 O-Ringe geliefert.
Motor with manifold mount is supplied with 2 O-rings.
Deux joints toriques sont livrés avec les moteurs au plan de raccordement universel.
Il blocchetto connessioni è corredato da 2 OR.

Gewicht / Weight		TH140	TH170	TH195	TH240	TH280	TH335	TH405	TH475	TH530	TH625	TH785	TH960
Poids / Peso	kg	18.6	18.8	19.0	19.4	19.8	20.2	20.8	21.4	22.2	22.9	24.5	26.1
Code	"L1" mm	241	244	247	252	257	263	270	279	285	295	314	333
B, X, L, A, Y	"L2" mm	198	202	205	209	214	221	228	237	243	252	271	290

TH 140

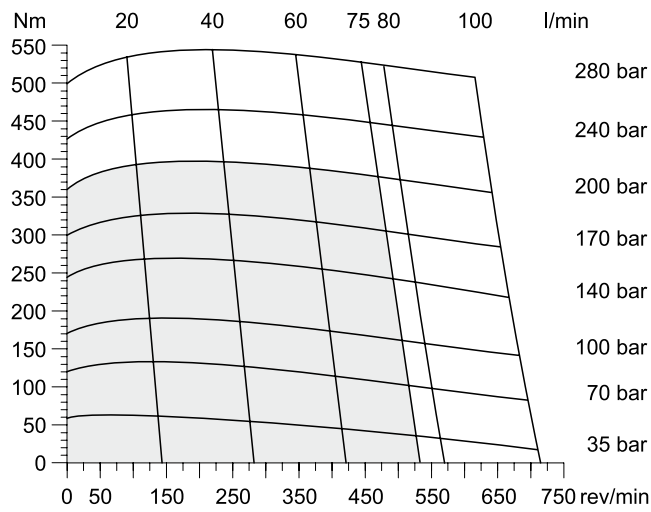

TH 170

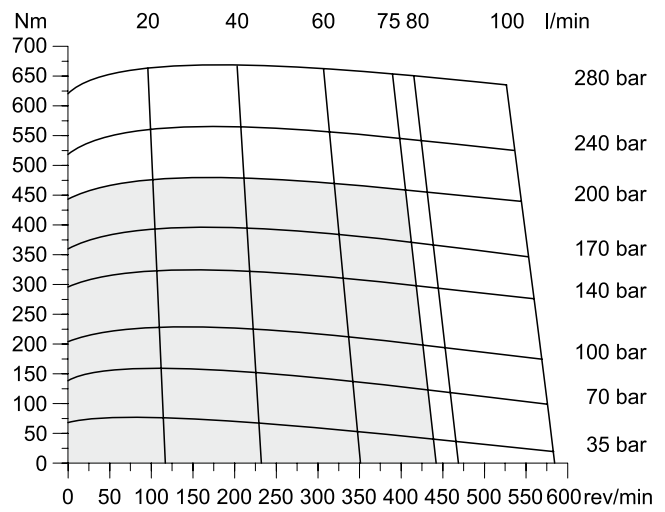

TH 195

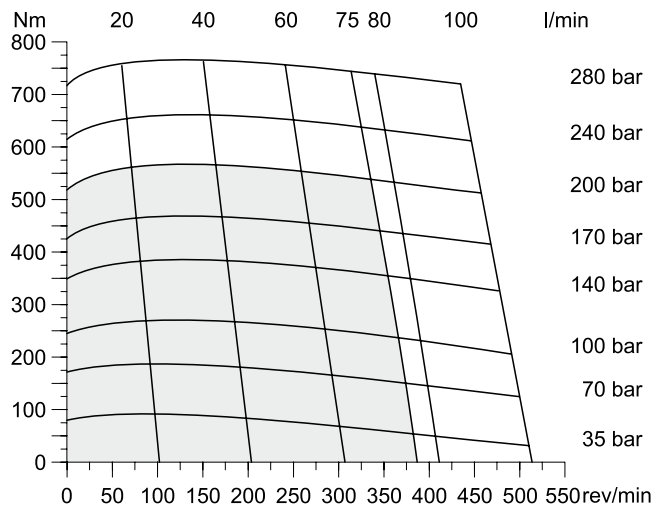

TH 240

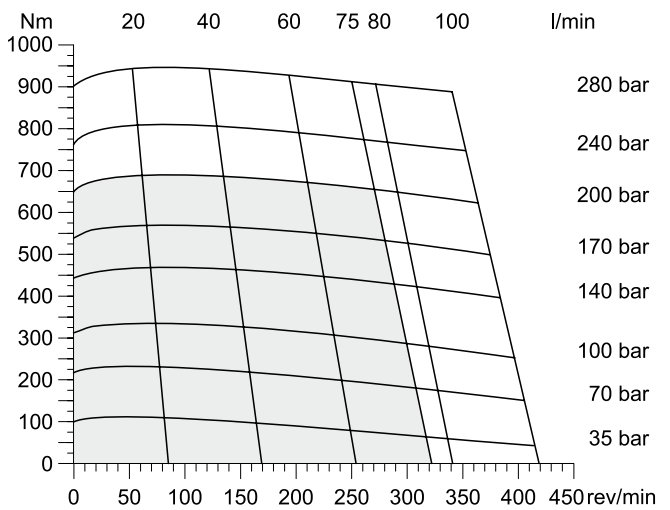

TH 280

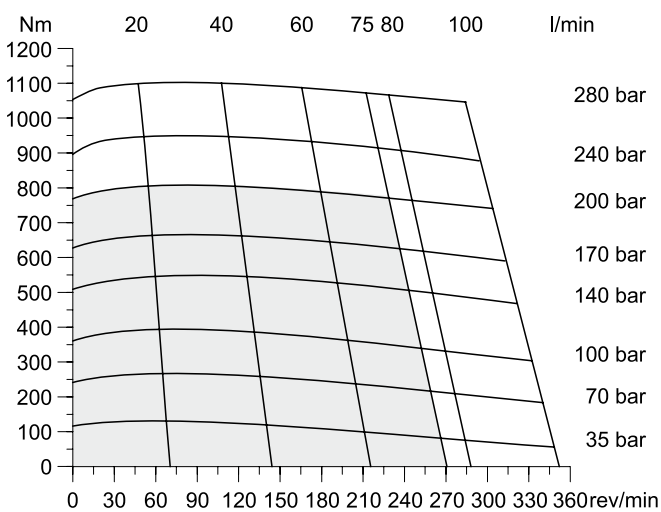

TH 335

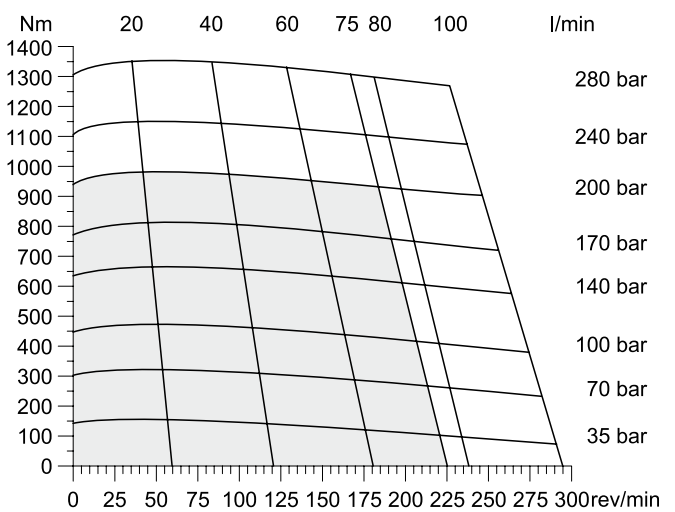

□ Cont. □ Int.

int. =
Intermittierende Werte maximal: 10% von jeder Betriebsminute.
Intermittent operation rating applies to 10% of every minute.
Fonctionnement interm.: 10% max. de chaque minute d'utilisation.
Servizio intermittente: 10% max di ogni minuto di utilizzazione.

TH 405

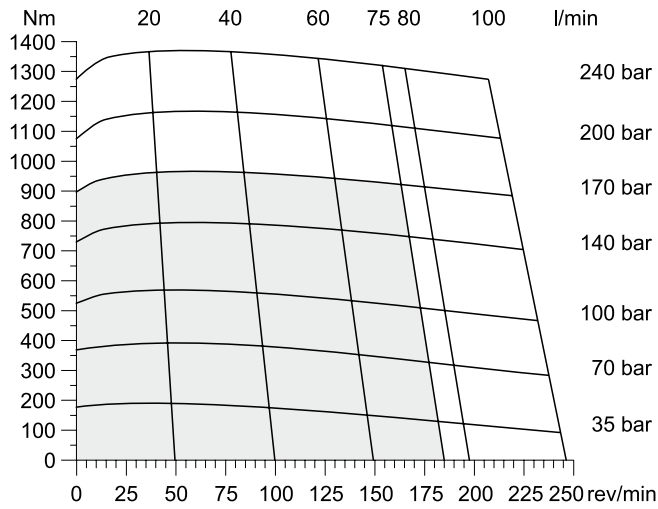

TH 475

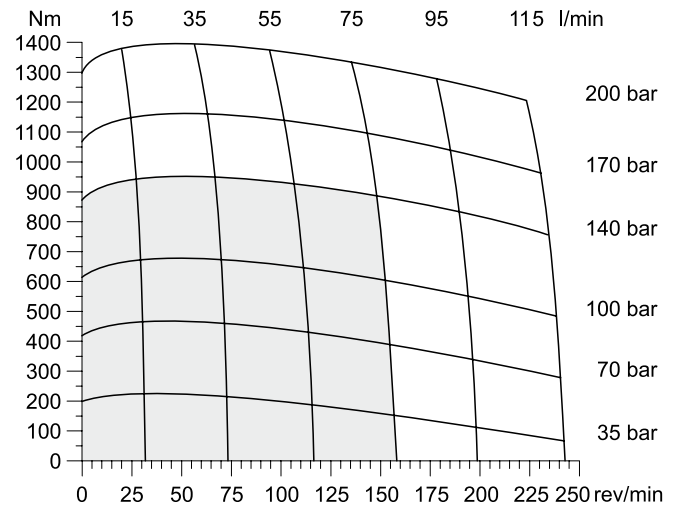

TH 530

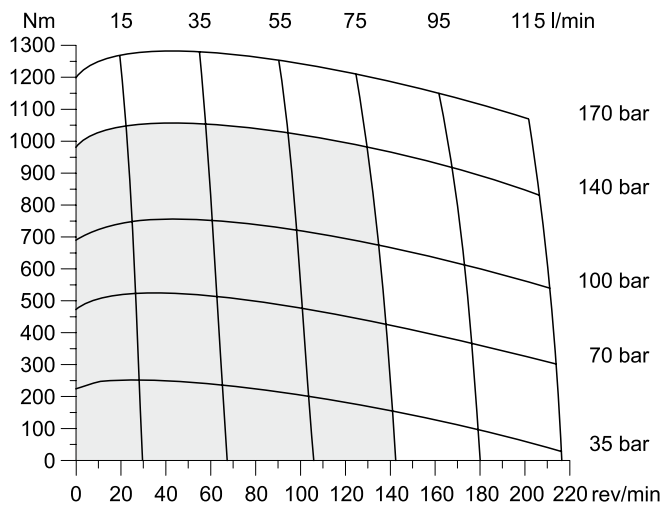

TH 625

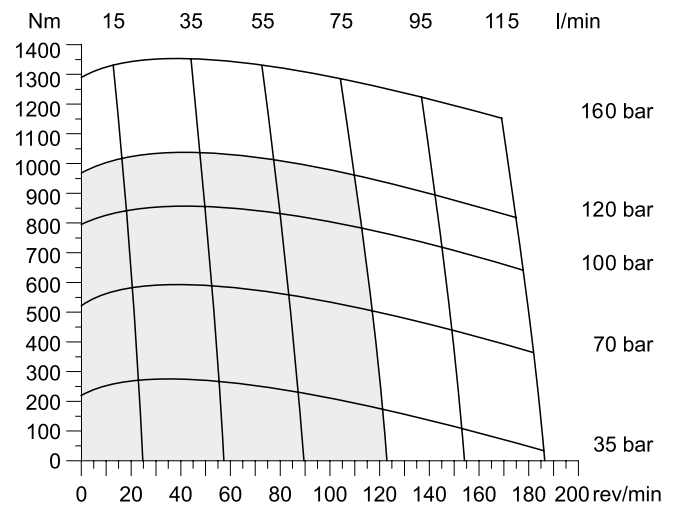

TH 785

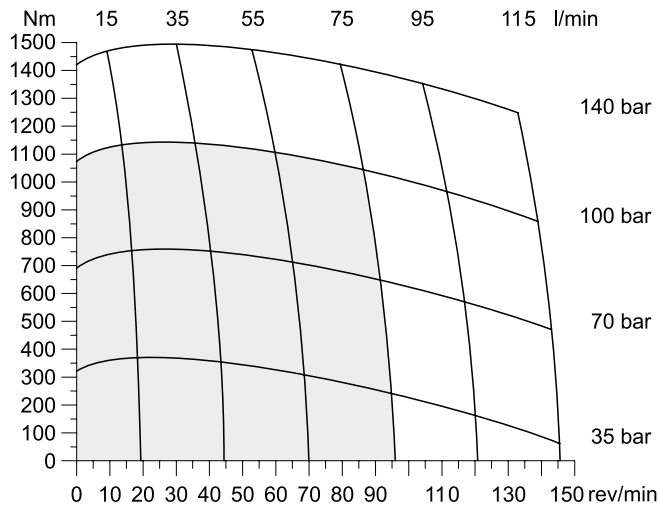

TH 960

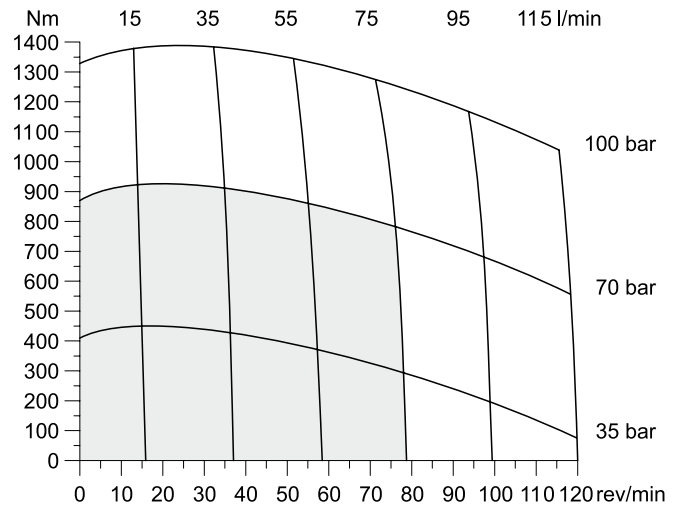

□ Cont. □ Int.

int. =
Intermittierende Werte maximal: 10% von jeder Betriebsminute.
Intermittent operation rating applies to 10% of every minute.
Fonctionnement interm.: 10% max. de chaque minute d'utilisation.
Servizio intermittente: 10% max di ogni minuto di utilizzazione.

Life Time

Code M

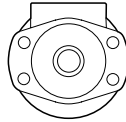
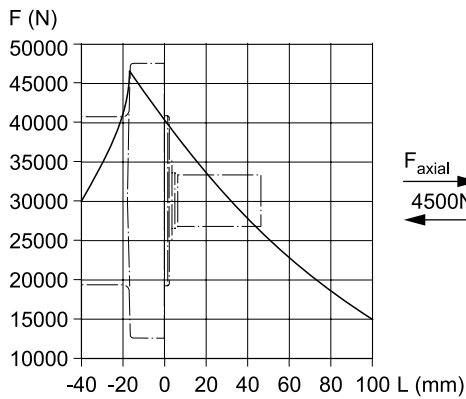

$$L_h = \frac{\left(\frac{1500000}{F_R \cdot \left(1.20 + \frac{L}{95\text{mm}} \right)} \right)^{3.3}}{n}$$

Code U

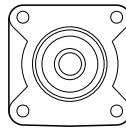
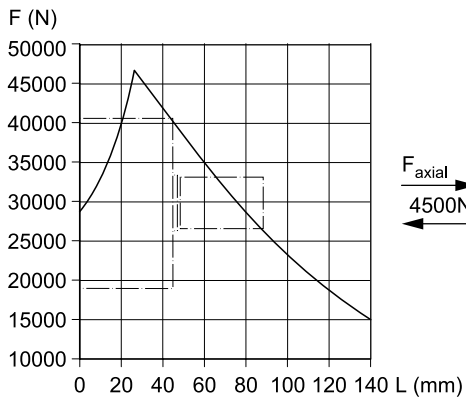

$$L_h = \frac{\left(\frac{1500000}{F_R \cdot \left(0.76 + \frac{L}{95\text{mm}} \right)} \right)^{3.3}}{n}$$

Die Lebensdauer der Radiallager (L_h in Stunden) lässt sich nach folgender Formel berechnen. Die Größe F_R ist durch die mechanische Festigkeit der Abtriebswelle begrenzt (siehe Diagramm). Das Maß "L" ist das Längenmaß vom Gehäuseflansch bis zum Angriffspunkt der Radialkraft F_R .

La durée de vie des roulements radiaux (L_h en heures) peut être calculée par les formules suivantes. La grandeur F_R est limitée par les résistances mécaniques de l'arbre de sortie (voir diagramme). La cote "L" est la longueur entre la bride du carter jusqu'au point d'appui de l'effort radial F_R .

Life time (L_h in hours) of the radial bearings can be calculated with the following formula. The value F_R is limited by the mechanical strength of the shaft (see diagram). The measurement "L" is the length from the housing flange up to the point of impact of the radial force F_R .

La durata dei cuscinetti (L_h in ore) può essere calcolata con la seguente formula. Il valore F_R è limitato dalla resistenza meccanica dell'albero (vedi diagramma). La quota "L" è la distanza tra la flangia del corpo ed il punto di applicazione della forza radiale F_R .

Vorstehende Formeln gelten für eine B10-Lebensdauer.
The preceding formulas are valid for a B10 duration of life.
Les formules précédentes sont valables pour une durée de vie B10.
Le formule precedenti sono valide per una durata della vita B10.

L_h = h
 L = mm
 F_R = F (N)
 n = rev/min

Ordering Code

**Torqmotor
Series TH**

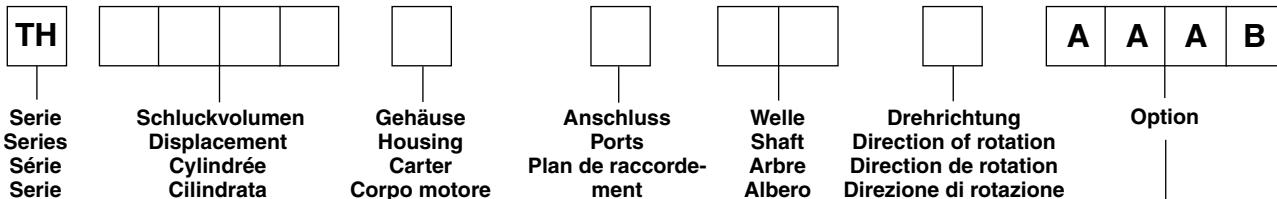

Code	cm ³ /rev
0140	140
0170	169
0195	195
0240	237
0280	280
0335	337
0405	405
0475	476
0530	529
0625	624
0785	786
0960	958

Code	Housing
M	
U	

Code	Front port
S	7/8-14 UNF O-Ring
W ¹⁾	G 1/2

¹⁾ Nicht verfügbar für Gehäuse "U"
Not possible for housing "U"
Pas disponible pour carter "U"
Non Disponibile con il corpo codice "U"

Code	Rear port
Y	G 1/2 Axial
A	7/8-14 UNF Axial
X	G 1/2 Radial
B	7/8-14 UNF Radial
L	Universal Radial M8x13

Code	Shaft
31	
32	

For further options different to standard 'AAAB' see page 57.

Code	Front port
0	 Standard
1	

Code	Rear port
0	 Standard
1	